

4

3

2

1

D

D

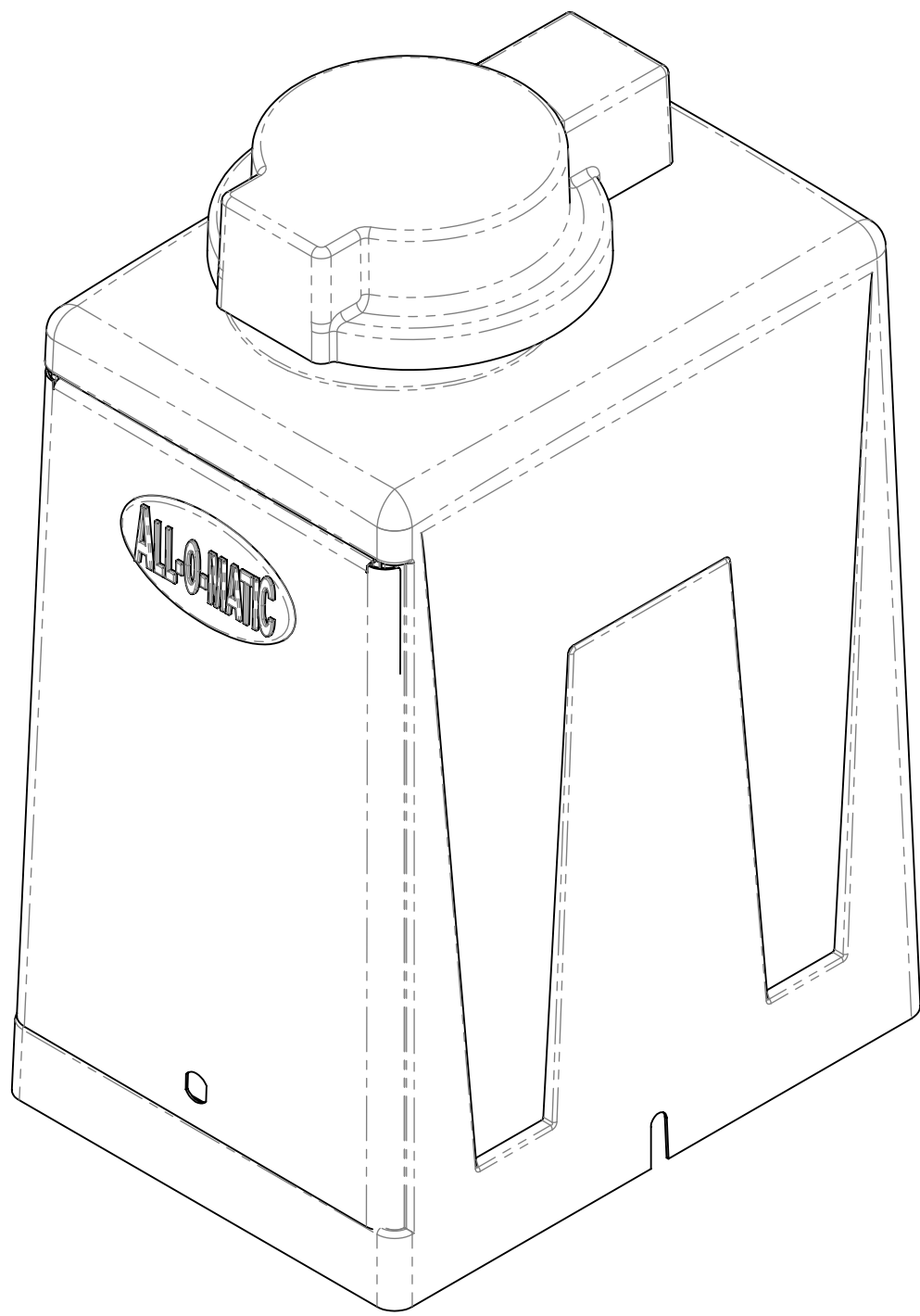

C

C

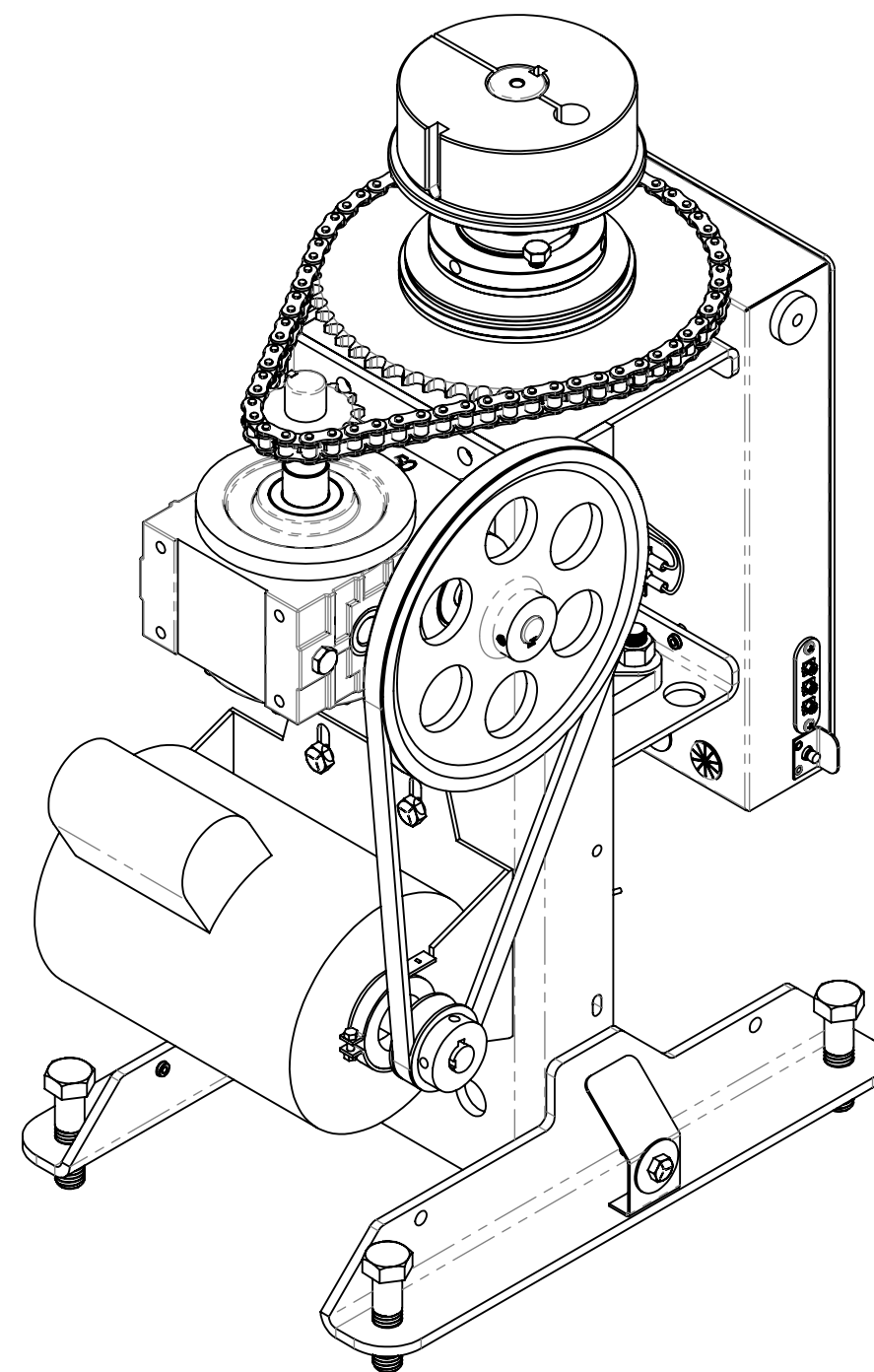

B

B

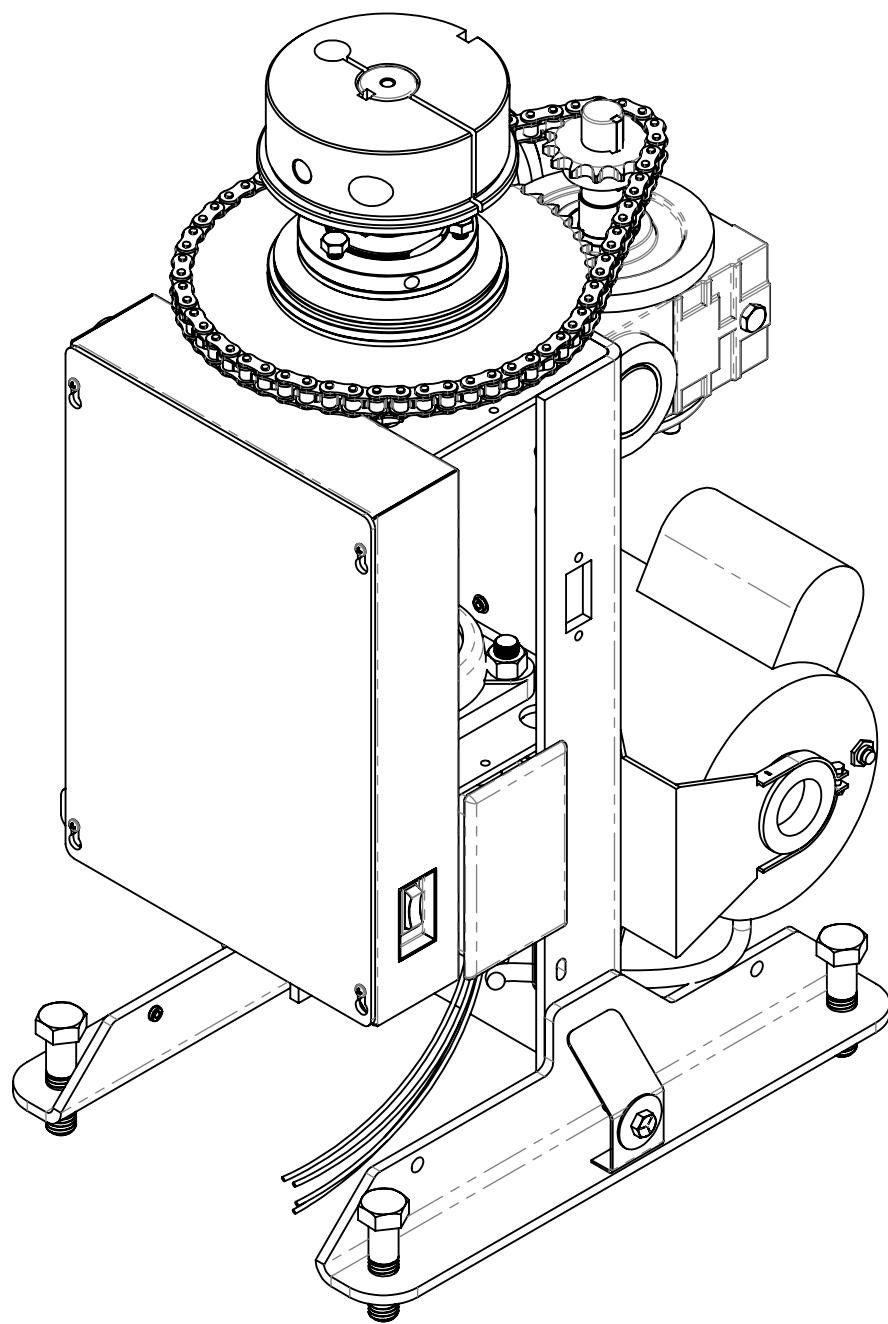

A

A

ITEM NO.	DESCRIPTION	PART NUMBER	QTY.
1	FRAME ONLY	SW-300FM	1
2	GEARBOX	GBX-300	1
3		40-0.5P1ST14T14SO1.660H.717L0.875OS1	1
4	GEARBOX PULLEY	PLY-8	1
5	1/2 HP AC MOTOR	MTR-1050	1
6	MOTOR PULLEY	PLY-2	1
7	BELT	4L-370 (AX35)	1
8	CONTROL BOX ASSEMBLY	CBX-AY301	1
9	CONTROL BOX	CBX-301	1
10	CONTROL BOX COVER	CBC-101	1
11	CONTROL BOX RADIO RECEIVER STRIP	COM-1003	1
12	CONTROL BOX RESET PUSH BUTTON	COM-1004	1
13	CONTROL BOX AC CONTROL BOARD	ACPCB-UL	1
14	CONTROL BOX ALARM BUZZER	COM-1005	1
15	CONTROL BOX ON/OFF POWER SWITCH	COM-1000	1
16	POWER SUPPLY BOX 110VAC OUTLET	COM-1001	1
17	CONTROL BOX 14 PIN TERMINAL STRIP	COM-1002	1
18	LIMIT SWITCH ASSEMBLY	LSA-AY300	1
19	LIMIT SWITCH	COM-1007	2
20	LIMIT SWITCH WIRE HARNESS	LSH-300	1
21	LIMIT SWITCH COLLAR	COM-1012	2
22	POWER SUPPLY BOX ASSEMBLY	PSB-AY301	1
23	POWER SUPPLY BOX	PSB-300AC	1
24	POWER SUPPLY BOX WIRE HARNESS	PSH-301	1
25	POWER BOX COVER	PBC-300	1
26	TORQUE LIMITER ASSEMBLY	TLA-AY300	1
27	TORQUE LIMITER COLLAR	TLC-300	1
28	TORQUE LIMITER FRICTION DISC X2	TLD-300	2
29	TORQUE LIMITER DISC WASHER X2	TLW-300	2
30	TORQUE LIMITER PLATE	TLP-300	1
31	TORQUE LIMITER PRESSURE PLATE	TPP-300	1
32	TORQUE LIMITER ROUND NUT	TLN-300	1
33		40-0.5P1ST54T54SN3.OH2.OL2.9375N	1
34	TORQUE LIMITER BUSHING	TLB-300	1
35	TORQUE LIMITER CHAIN	41NPX18	1
36	DRIVE SHAFT BEARING	BRG-207F	2
37	DRIVE SHAFT	DST-301	1
38	EXTERIOR PLASTIC COVER WITH ACCESS DOOR	EPC-300D	1
39	EXTERIOR PLASTIC HUB COVER	EPC-S300	1
40	SWINGER ALUMINUM HUB	COM-1011	1

ALL-O-MATIC, Inc.
 7820 Gloria Ave. Phone: (818) 787-1988
 Van Nuys CA, USA 91406
 EMAIL: fortino@allomatic.net

DIMENSIONS ARE IN INCHES
 BREAK SHARP EDGES 10-40
 MACHINED SURFACE FINISH IS
 1.6 MICROMETERS
 DO NOT SCALE DRAWING

THE INFORMATION DISCLOSED HEREIN WAS ORIGINATED BY
 AND IS THE PROPERTY OF ALL-O-MATIC, INC. AND ALL PATENT,
 PROPRIETARY, DESIGN, USE, SALE, MANUFACTURING, AND
 REPRODUCTION RIGHTS THERE TO ARE RESERVED BY
 ALL-O-MATIC, INC.

DRAWN BY: S. HUERTA DATE: 01/14/2022 CHECKED BY: DATE CHECKED:
 MATERIAL: RAW MAT:
 TITLE: **SW-300AC Assembly**

SYMBOL	ECO#	ENGINEERING CHANGE ORDER REVISION DESCRIPTION	BY	CKD	DATE	SHEET 1 OF 2	SCALE: 1:4	DRAWING SIZE: C	PART#:
--------	------	---	----	-----	------	--------------	------------	-----------------	--------

4

3

2

1

4

3

2

1

CONTROL BOX ASSEMBLY: CBX-AY301 (8)

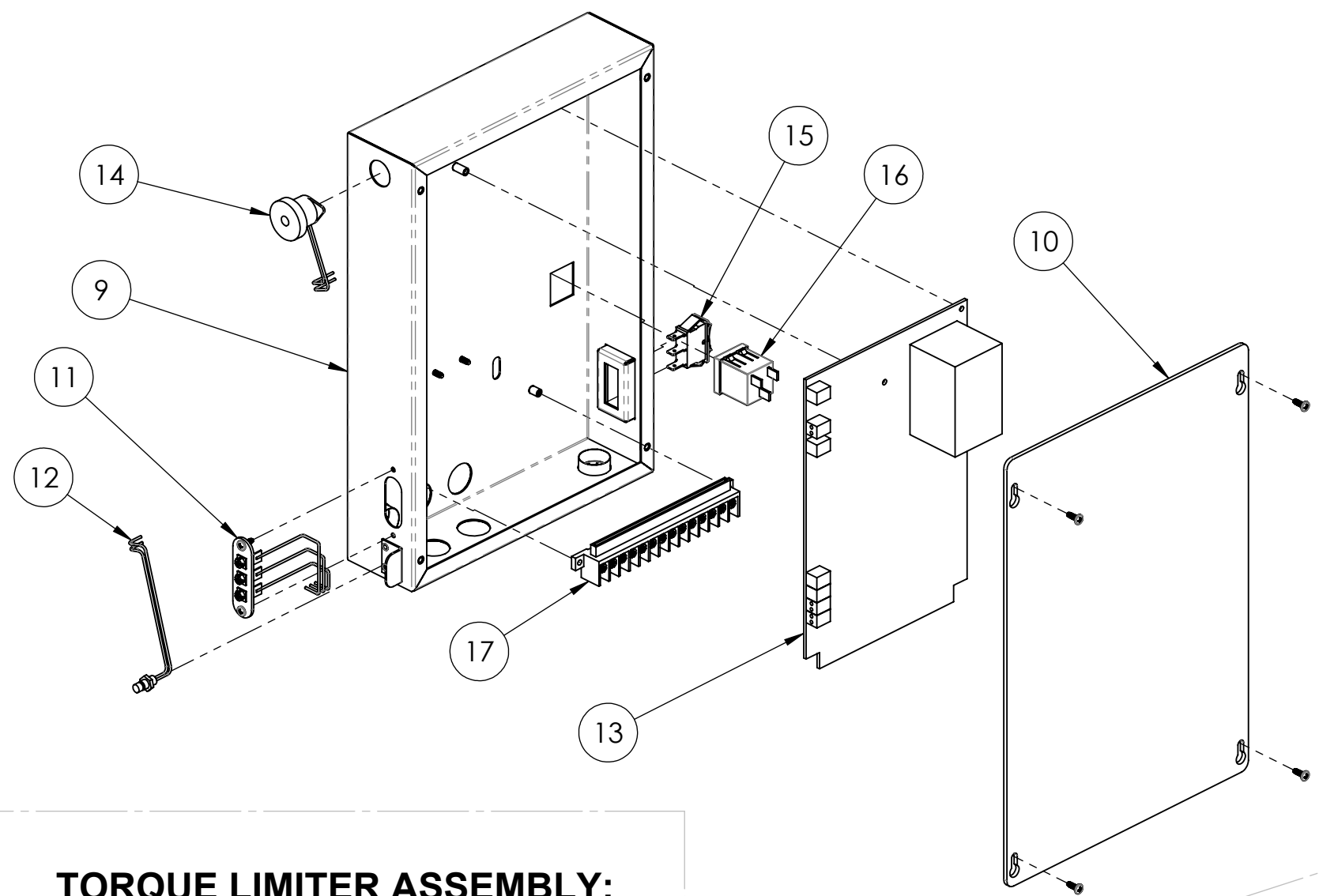

LIMIT SWITCH ASSEMBLY: LSA-AY300 (18)

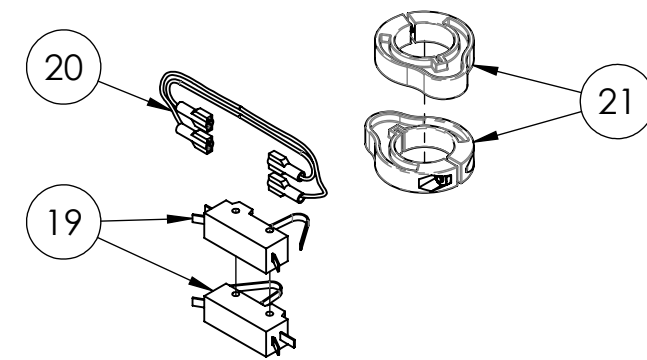

POWER SUPPLY BOX ASSEMBLY: PSB-AY301 (22)

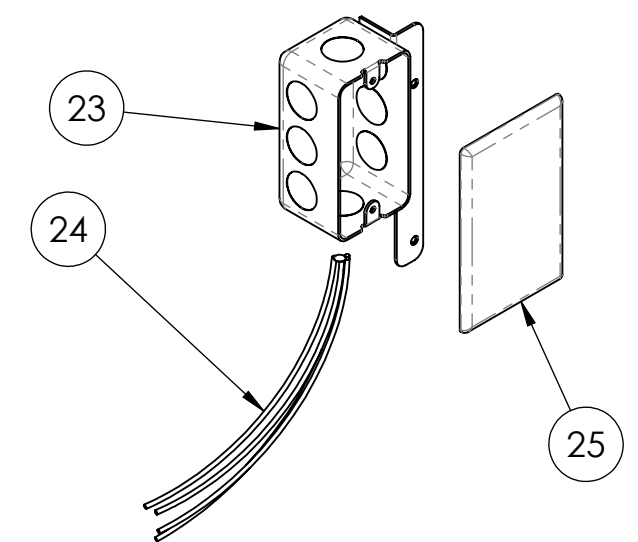

TORQUE LIMITER ASSEMBLY: TLS-AY300 (26)

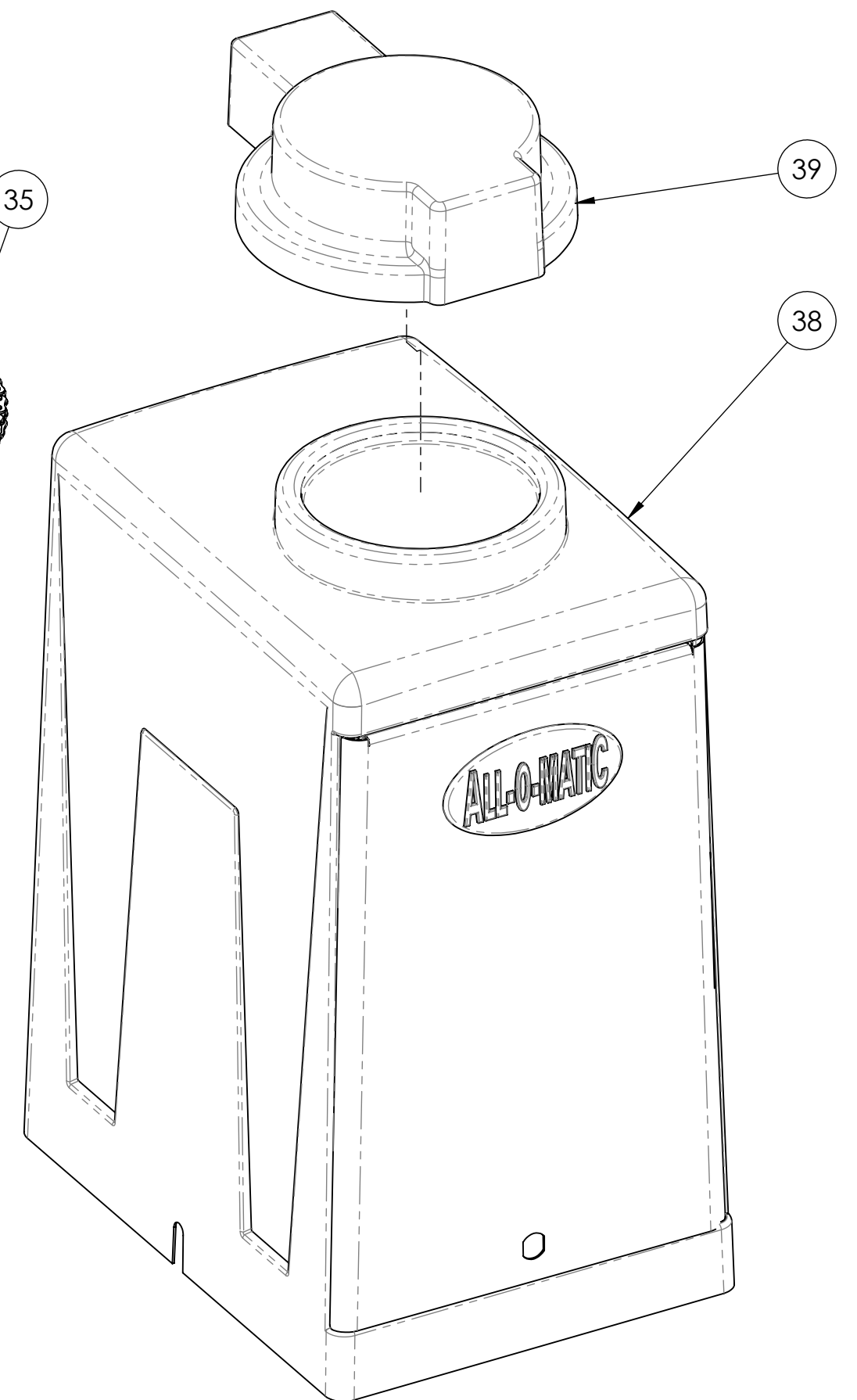
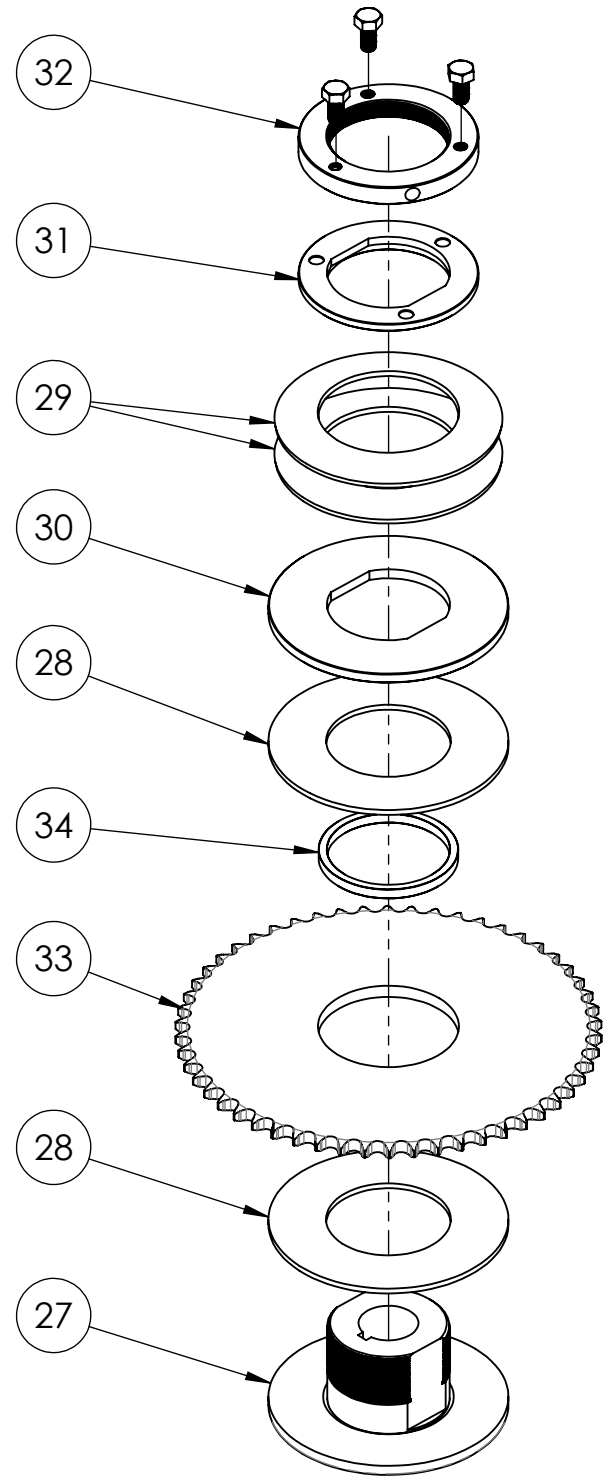
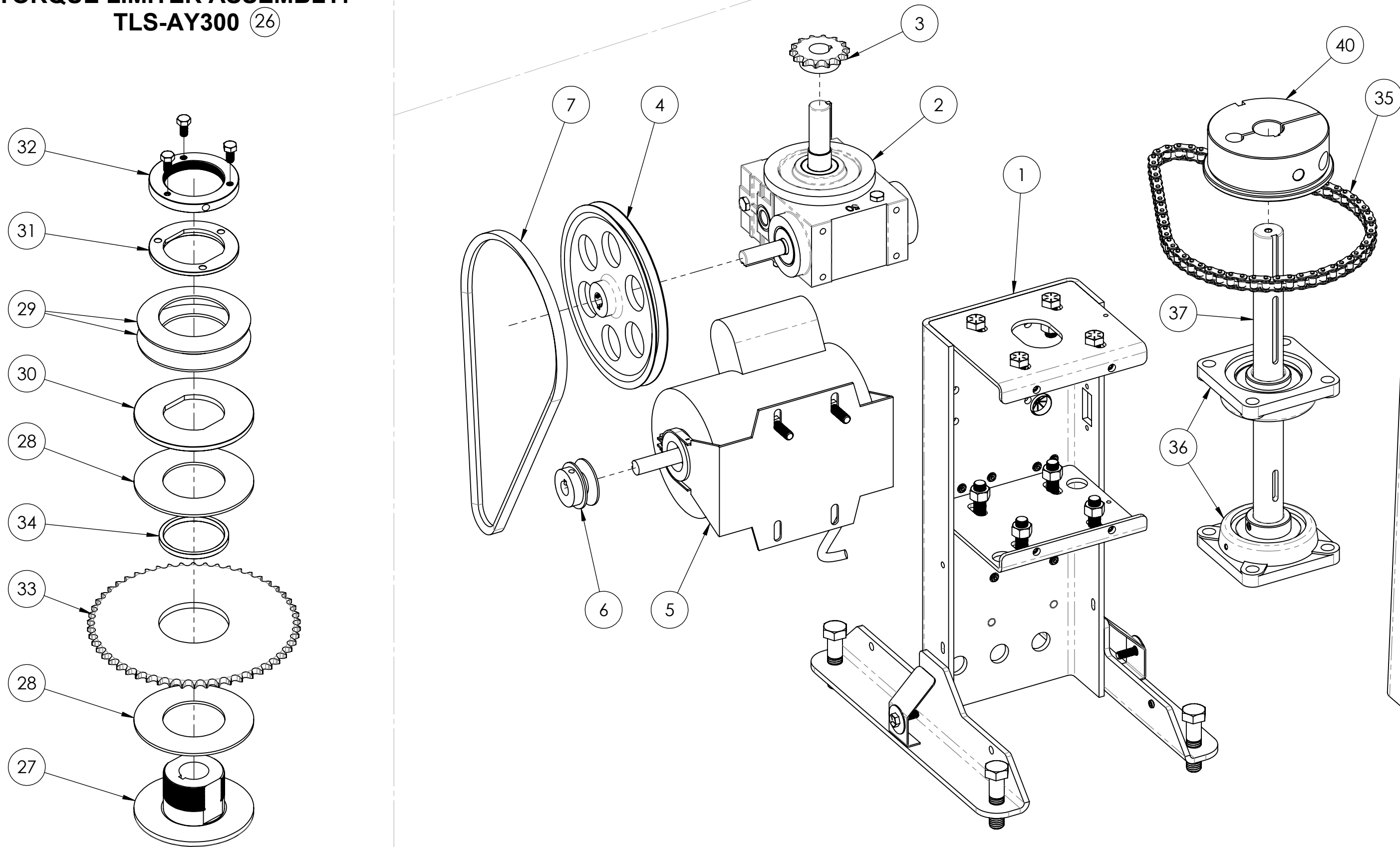

4

3

2

1