



Swing Gate Installation Manual

Eagle-200 Series

Eagle-100 Series

Eagle Access Control Systems, Inc.

(800)708-8848

www.eagleoperators.com

Operator installation and instructions for the
Eagle-200 and Eagle-100 Series.



UL325 and UL991 Compliant

Table of Contents

Contents:	Page(s):
UL Listings	Page 3/4
Installing the Warning Sign / Precautions	Page 5
Methods of Installation / Compact Installation	Page 6
Aligning the Easy Release Arm	Page 7
Mounting the Secondary Entrapment	Page 7
Welding the Gate Arm	Page 7
Mounting Operator(s) to Concrete Pads	Page 8
Selecting the Opening Direction of Gate	Page 8
Connecting the Power	Page 9
Reverse / Exit Loop Installations	Page 9
Two Way Adjustable Reverse Sensors / ERD	Page 10
The Feature Selector	Page 11
Master and Slave Operation	Page 12
Master Control Options	Page 12
Slave Control Options	Page 13
Selecting the Delay Functions	Page 13
Output Connections	Page 14
MAG Lock Solenoid	Page 14
Alarm	Page 14
24 VAC Auxiliary Power	Page 14
Connecting the Accessories	Page 15
Description of Inputs	Page 16
Receiver Connections	Page 17
Gate Travel Distance / Setting the Limit Switches	Page 17
Emergency Release	Page 18
Resetting the Motor	Page 18
Adjusting the Operator's Clutch	Page 18
Control Board LED Indicators	Page 19
Troubleshooting	Page 20
Parts Breakdown / Eagle-200	Page 21
Parts Breakdown / Eagle-100	Page 22
Operator Parts List / Eagle-200 & Eagle-100	Page 23

© 2005 Eagle Access Control Systems, Inc.

All rights reserved. No part of this manual may be reproduced in any means: graphics, electronics, or mechanical, including photocopying without the expressed written permission of the publisher. Materials, components and specifications are subject to change without notice.

IMPORTANT SAFETY INSTRUCTIONS

A. **WARNING** – To reduce the risk of injury or death:

- 1) **READ AND FOLLOW ALL INSTRUCTIONS.**
- 2) Never let children operate or play with gate controls. Keep the remote control away from children.
- 3) Always keep people and objects away from the gate. **NO ONE SHOULD CROSS THE PATH OF THE MOVING GATE.**
- 4) Test the gate operator monthly. The gate **MUST** reverse on contact with a rigid object or stop when an object activates the non-contact sensors. After adjusting the force or the limit of travel, retest the gate operator. Failure to adjust and retest the gate operator properly can increase the risk of injury or death.
- 5) Use the emergency release only when the gate is not moving.
- 6) **KEEP GATES PROPERLY MAINTAINED.** Read the owner's manual. Have a qualified service person make repairs to gate hardware.
- 7) The entrance is for vehicles only. Pedestrians must use separate entrance.
- 8) **SAVE THESE INSTRUCTIONS.**

A. Install the gate operator only when:

- 1) The operator is appropriate for the construction of the gate and the usage Class of the gate,
- 2) All openings of a horizontal slide gate are guarded or screened from the bottom of the gate to a minimum of 4 feet (1.22 m) above the ground to prevent a 2-1/4 inch (57.2 mm) diameter sphere from passing through the openings anywhere in the gate, and in that portion of the adjacent fence that the gate covers in the open position,
- 3) All exposed pinch points are eliminated or guarded, and
- 4) Guarding is supplied for exposed rollers.

B. The operator is intended for installation only on gates used for vehicles. Pedestrians must be supplied with a separate access opening. The pedestrian access opening shall be designed to promote pedestrian usage. Locate the gate such that persons will not come in contact with the vehicular gate during the entire path of travel of the vehicular gate.

C. The gate must be installed in a location so that enough clearance is supplied between the gate and adjacent structures when opening and closing to reduce the risk of entrapment. Swinging gates shall not open into public access areas.

D. The gate must be properly installed and work freely in both directions prior to the installation of the gate operator. Do not over-tighten the operator clutch or pressure relief valve to compensate for a damaged gate.

E. For gate operators utilizing Type D protection:

- 1) The gate operator controls must be placed so that the user has full view of the gate area when the gate is not moving.
- 2) The placard provided marked in letters at least 1/4-in (6.4-mm) high with the word "WARNING" and the following statement or the equivalent: "Moving Gate Has the Potential of Inflicting Injury or Death – Do Not Start Gate Unless Path is Clear" shall be placed adjacent to the controls,
- 3) An automatic closing device (such as a timer, loop sensor, or similar device) shall not be employed, and
- 4) No other activation device shall be connected.

F. Controls intended for user activation must be located at least six feet (6') away from any moving part of the gate and where the user is prevented from reaching over, under, around or through the gate to operate the controls. Outdoor or easily accessible controls shall have a security feature to prevent unauthorized use.

G. The Stop and/or Reset button must be located in the line-of-sight of the gate. Activation of the reset control shall not cause the operator to start.

H. A minimum of two (2) **WARNING SIGNS** shall be installed, one on each side of the gate where easily visible.

I. For gate operators utilizing a non-contact sensor in accordance Usage Class:

- 1) See instructions on the placement of non-contact sensors for each Type of application,
- 2) Care shall be exercised to reduce the risk of nuisance tripping, such as when a vehicle, trips the sensor while the gate is still moving, and
- 3) One or more non-contact sensors shall be located where the risk of entrapment or obstruction exists, such as the perimeter reachable by a moving gate or barrier.

J. For a gate operator utilizing a contact sensor in accordance with Usage Class:

- 1) One or more contact sensors shall be located where the risk of entrapment or obstruction exists, such as at the leading edge, trailing edge, and post-mounted both inside and outside of a vehicular horizontal slide gate.
- 2) One or more contact sensors shall be located at the bottom edge of a vehicular vertical lift gate.

UL Listings (continued)

- 3) One or more contact sensors shall be located at the pinch point of a vehicular vertical pivot gate.
- 4) A hardwired contact sensor shall be located and its wiring arranged so that the communication between the sensor and the gate operator is not subjected to mechanical damage.
- 5) A wireless contact sensor such as one that transmits radio frequency (RF) signals to the gate operator for entrapment protection functions shall be located where the transmission of the signals are not obstructed or impeded by building structures, natural landscaping or similar obstruction. A wireless contact sensor shall function under the intended end-use conditions.
- 6) One or more contact sensors shall be located on the inside and outside leading edge of a swing gate. Additionally, if the bottom edge of a swing gate is greater than 6 inches (152 mm) above the ground at any point in its arc of travel, one or more contact sensors shall be located on the bottom edge.
- 7) One or more contact sensors shall be located at the bottom edge of a vertical barrier (arm).

UL 325 MODEL CLASSIFICATIONS

Class I (Residential vehicular gate operator) - A vehicular gate operator (opener or system) intended for use in a home of one to four single family dwellings, or a garage or parking area associated therewith.

Class II (Commercial / General access vehicular gate operator) - A vehicular gate operator (opener or system) intended for use in a commercial location or building such as a multi-family housing unit (five or more single family units), hotel, garages, retail store, or other buildings servicing the general public.

Class III (Commercial / General access vehicular gate operator) - A vehicular gate operator (opener or system) intended for use in an industrial location, loading dock area, or other location not intended to service the general public.

Class IV (Commercial / General access vehicular gate operator) - A vehicular gate operator (opener or system) intended for use in a guarded industrial location or buildings such as airport security area or other restricted access locations not servicing the general public, in which unauthorized access is prevented via supervision by security personnel

Installing the Warning Sign



Precautions



Eagle swing gate operators are for vehicular use only!
They are not for pedestrian use!



Be sure to mount ALL operating devices clearly out of reach through gate.

Regarding Ornamental Grill Styled Gates: Injuries may be avoided if a mesh or screen is installed on the gate. Injuries resulting from hands and feet becoming stuck in gate or children riding the gate while in movement, can be greatly reduced if this "screen" or "mesh" is applied to gate as a safety precaution.



CAUTION! Be sure to read and follow all the Eagle Access Control Systems, Inc. and UL instructions before installing and operating any Eagle Access Control Systems, Inc. products. Eagle Access Control Systems, Inc. is not responsible for any improper installation procedures caused by failure to comply with local building codes.



Methods of Installation



An experienced installer should perform the installation of all operators. Improper installation may result in property damage, severe injury, or death. Read entire manual before proceeding with the installation.

Installation for the Eagle-200 Series & Eagle-100 operators:

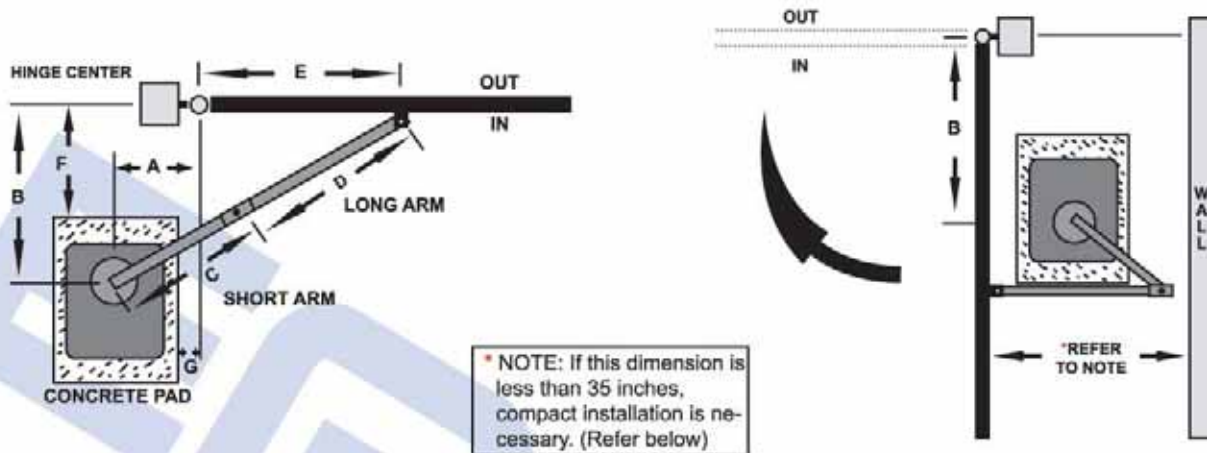

Swing Dimensions

	A	B	C	D	E
1	12	28	27.5	34.5	42
2	12	30	29.5	36	43
3	12	32	25.5	39	44
4	12	35	29	36	45

Placement of Concrete Pad in relation to Gate:

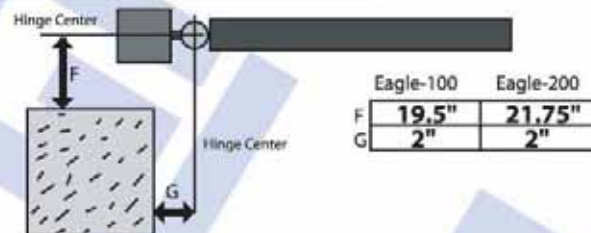

Compact Installation

The following dimensions are for **COMPACT INSTALLATIONS** only!

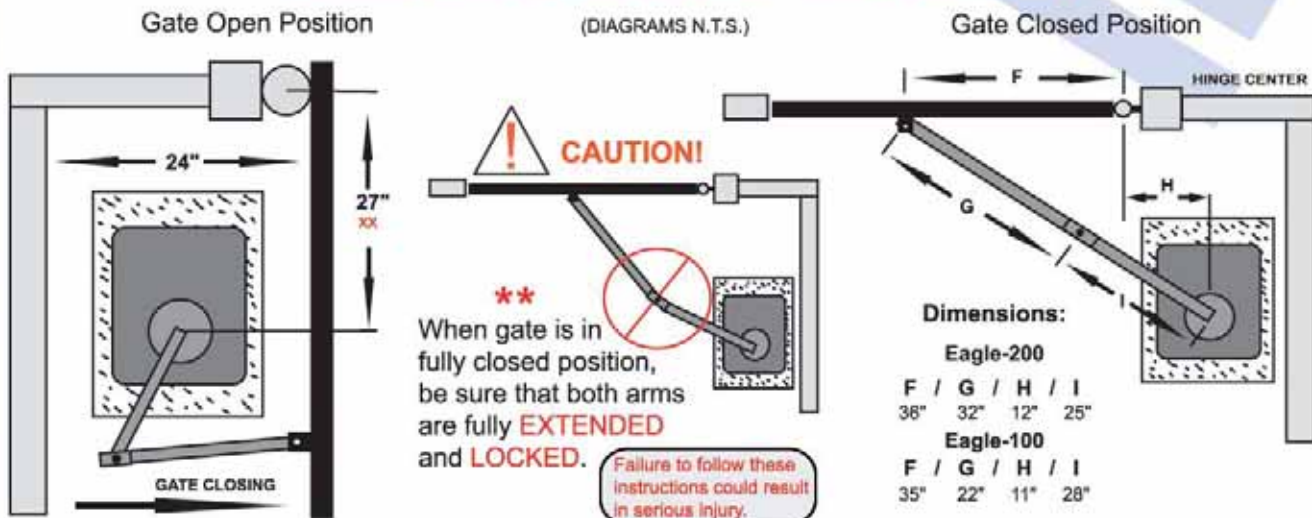

xx - Change dimension to 26" for the Eagle-100

Aligning the Easy Release Arm

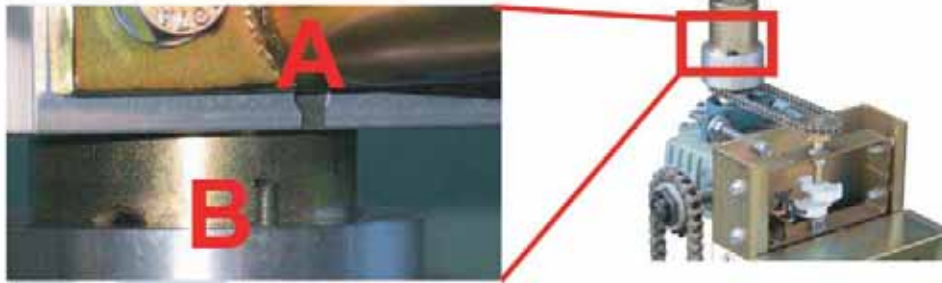

When aligning the Easy-Release Arm, the Slot A from the Arm portion must fit onto the Pin B of the operator.

Mounting The Secondary Entrapment

Note: Eagle Access Controls, Inc. recommends the installation of a reflective photocell sensor.



All Secondary Entrapment Sensors Are Connected To Edge Sensor Inputs

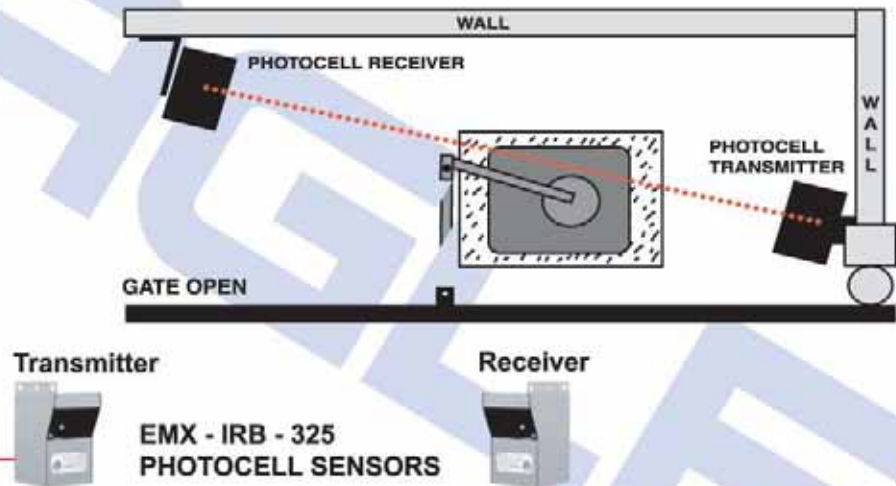

Welding The Gate Arm

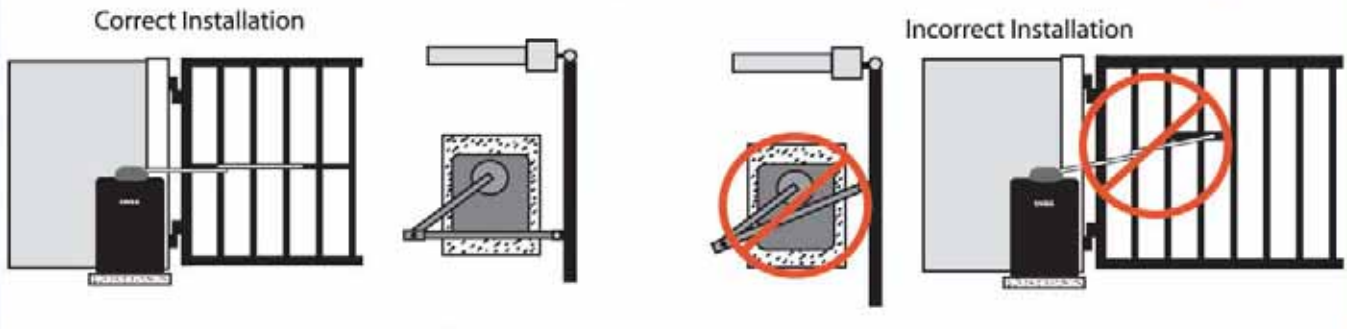

Once The Gate Arm Measurements Are Calculated:



Weld The Bracket On The Gate

Mounting Operator(s) To A Concrete Pad



Be sure that the operator is installed in a level position and is properly secured. Improper installation could result in property damage, injury, or death.

Note:

The following concrete recommendations are installation suggestions only. Please consult local codes for actual requirements in your area.

Recommended Dimensions

IMPORTANT!

The concrete dimensions shown are for the Eagle-200 only. For the Eagle-100 the recommended concrete pad dimensions are 24" x 20"

(Concrete Pad Diagram N.T.S.)

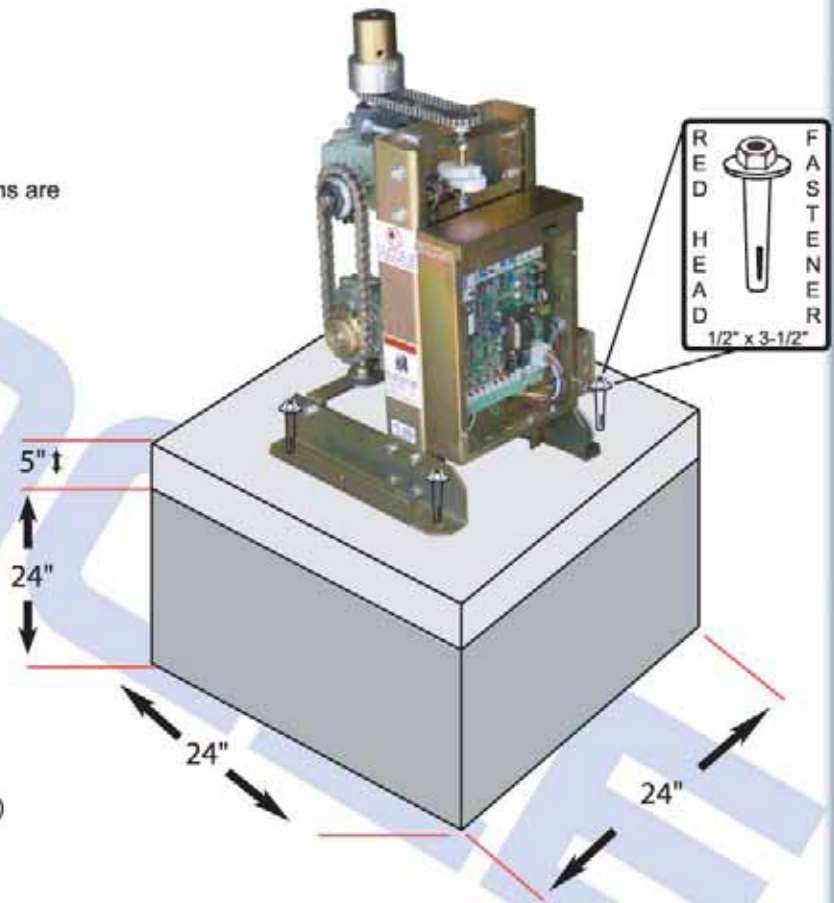

Selecting Opening Direction of Gate



To select the opening direction of the gate, use the Feature Selector (as shown). Use switch #2 to the "open left" position for left opening. Use switch #2 to the "open right" position for right opening.



OPEN TO THE RIGHT



OPEN TO THE LEFT



Connecting The Power



Be sure that the circuit breaker for the line input power is turned off before connecting the input power to the unit.

Connect 120 VAC, 15A, line input power to the wires provided in the power switch junction box located near the bottom of the operator.

120 VAC, 15A, convenience outlet is provided on side of operator.

Warning: Eagle Access Control Systems, Inc. is not responsible for researching and complying with local building codes. Be sure to check these codes before installation.



All units must be properly grounded

The wires are color coded as follows:

- Black - 120 VAC / Line Input Power
- White - Neutral Input
- Green - Ground Input (from an approved grounding method)

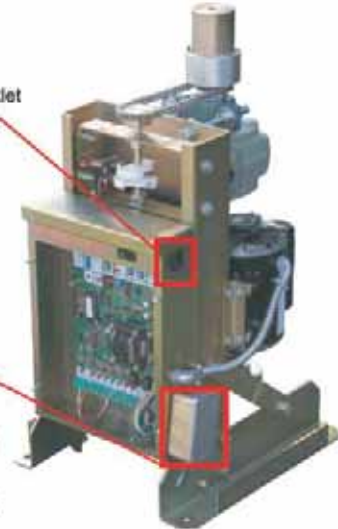

** Eagle recommends installing surge protection on all operators!

14 AWG	12 AWG	10 AWG	8 AWG	4 AWG
250 ft.	400 ft.	650 ft.	1000 ft.	2000 ft.

Reverse / Exit Loop Installation

The Purpose for a reversing loop is to prevent the gate from closing on a vehicle while it is exiting or stopped in the middle of the gate area. The purpose of the exit loop is to automatically open the gate when a vehicle approaches to exit.

Exit Loop Operation

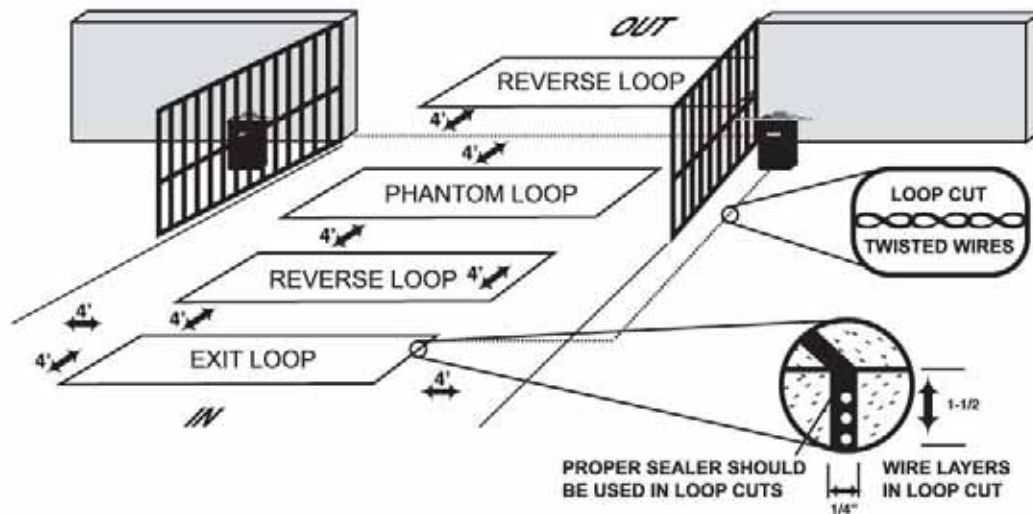

Wires must be wrapped inside the groove three times. Once you have completed the process, fill up the grooves with a proper seal.

Two Way Adjustable Reverse Sensor / ERD

CAUTION! 

Only a qualified service technician must make all adjustments to the sensor.

The Eagle Diamond Control Board has two separate pots for adjusting sensitivity. One is for opening the gate, and the other is for closing the gate.



IMPORTANT

The level of sensitivity has to do with the weight of the gate and the conditions of the installation.

There is an LED "OVERLOAD" warning that will light up when the gate is heavier than normal for the operator. During this warning, the operator will not function properly.



When Adjusting Sensors Remember...

Too Sensitive = if the gates stops or reverses by itself

Not Sensitive enough = if the gate strikes an object and does not stop or reverse



The Feature Selector

The selector uses an eight-station switch system that allows selection of the standard features and customized installation settings. The switch description is as follows:

Note: The power should always be turned off when designating feature selector switches

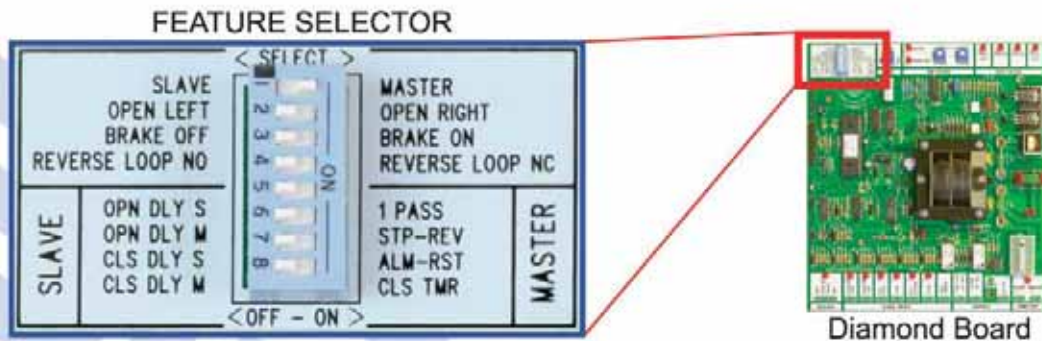

Switch 1: Slave/Master - Sets the operator to work as Master or Slave.

Switch 2: Gate Opening - Designates left or right opening.

Switch 3: Motor Brake - If the "on" position is selected, the gate will stop instantly when on the limit switches. This is useful on uphill / downhill applications and on all Fail-Safe operators.

Switch 4: Reverse Loop - Sets the reverse loop to be normally open or to normally close. It is useful in Fail-Safe applications.

Switch 5: One Pass (On/Off) - This tailgating feature works with the reverse loop to allow only one car to pass. After the car passes, the gate closes instantly. If a second car approaches the gate stops. The operator resumes closing after the car leaves.

Switch 6: Stop-Reverse (On/Off) - This radio feature allows the transmitter to work as a three-button station and is useful for a partial opening. If selected, the first command will open the gate, the second will stop the gate, and the third will close the gate.

Switch 7: Alarm Reset (On/Off) - If the "on" position is selected, after the five minutes "shut down" time period the operator will reset and any input will be accepted. Normally, the power must be turned off to reset.

Switch 8: Close Timer (On/Off) - Sets the Close Timer to the "on" or "off" position.

Master and Slave Operation

Important: Be sure that the 120VAC power (for the Master and the Slave) are connected to the same circuit breaker.

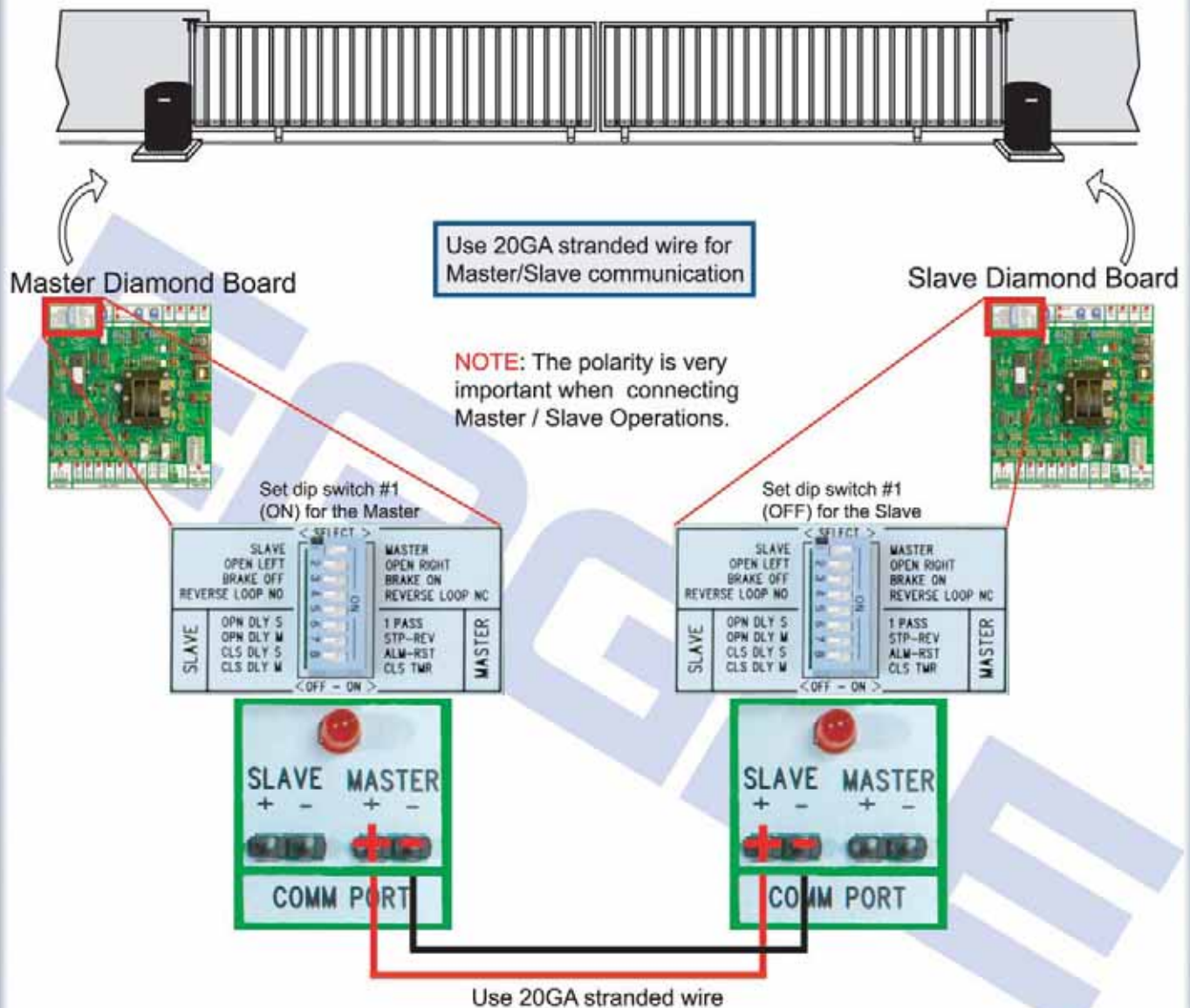

Master Control Options

Use the feature selector to choose available features by designating the various switches (1 through 8).

Gate opening direction, motor brake, reverse loop, one pass, stop reverse, alarm reset, and close timer.

Please refer to pages 10 & 11 for more information on individual switch functions.

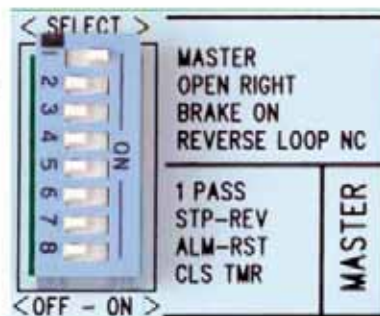

NOTE: Please remember the Eagle Diamond Control Board allows you to connect accessories to the Master or Slave operators.

These accessories include:
 Reverse Loop, Phantom Loop, Exit Loop, 3 Button Station, Key Switch Lock Box, Fire Dept. Box, Edge Sensors, Telephone System...Etc.

Slave Control Options

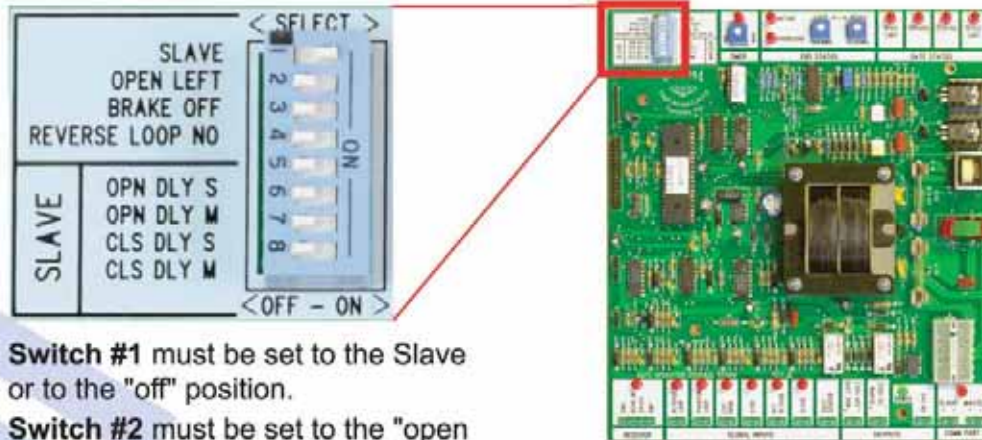

Switch #1 must be set to the Slave or to the "off" position.

Switch #2 must be set to the "open left" or to the "open right" position.

Switch #3 brake on / off.

Switch #4 Not in use.

Selecting The Delay Functions

The Eagle "Diamond" Control board was uniquely designed to allow the slave control to communicate to the master board all of the "Open-Delay" and "Close Delay" functions.

If no delay functions are needed, switches 5 through 8 must be in the off position.

Setting The Open Delay Function

Switches 5 & 6: Open Delay Slave (On/Off) - Selecting the switch to the "on" position delays the Slave (Sw. 5) or Master (Sw. 6) operator by 1 1/2 seconds on the open cycle. This is useful with magnetic lock applications.

Setting The Close Delay Function

Switches 7 & 8: Close Delay Master (On/Off) - Selecting the switch to the "on" position delays the Slave (Sw. 7) or Master (Sw. 8) operator by 1 - 6 seconds on the close cycle (adjustable by the Slave Timer shown below).



Diamond Control Board

Describing The Output Connections

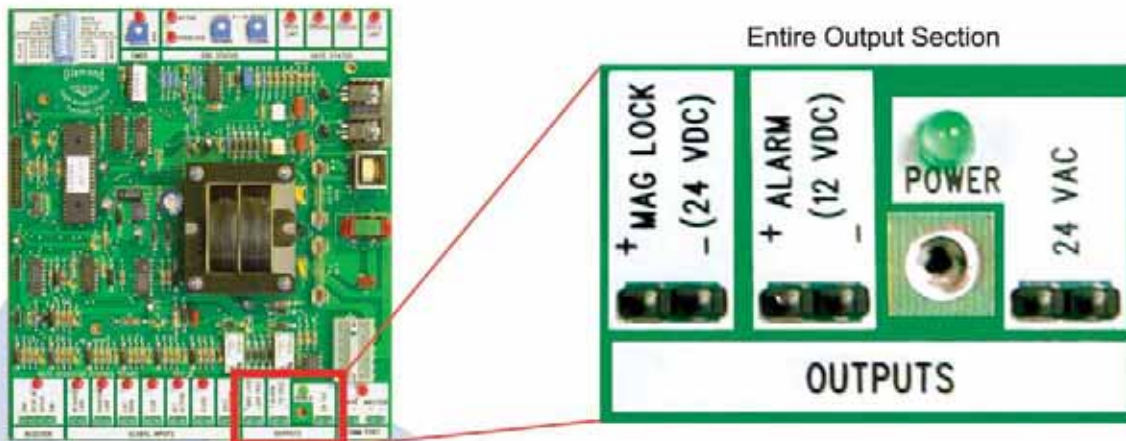

MAG Lock Solenoid Connections (24 VDC)

The Eagle Diamond Control Board provides a 24VDC and relay output for MAG Locks or Solenoids.



Alarm (12 VDC)

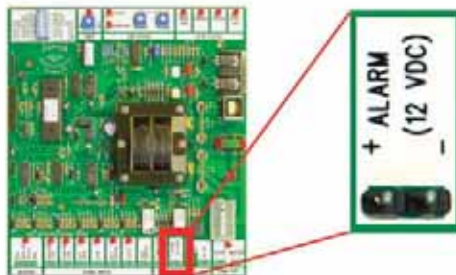

Safety Alarm: If the gate hits an obstruction twice while closing or opening, the system will shut down for 5 minutes. On the Diamond Board, you have two options of reset mode.

...
Selecting the "off" position will require a "manual reset" of the board if the previous happens. However, by selecting the "On" position, the system will automatically reset itself.

Power (24 VAC)

The Eagle Diamond Control Board provides 24 VAC Power, which can be used for loop detectors and receivers.



Connecting The Accessories

With the exception of the MAG Lock, all of these accessories can be installed on the Master or Slave operator.

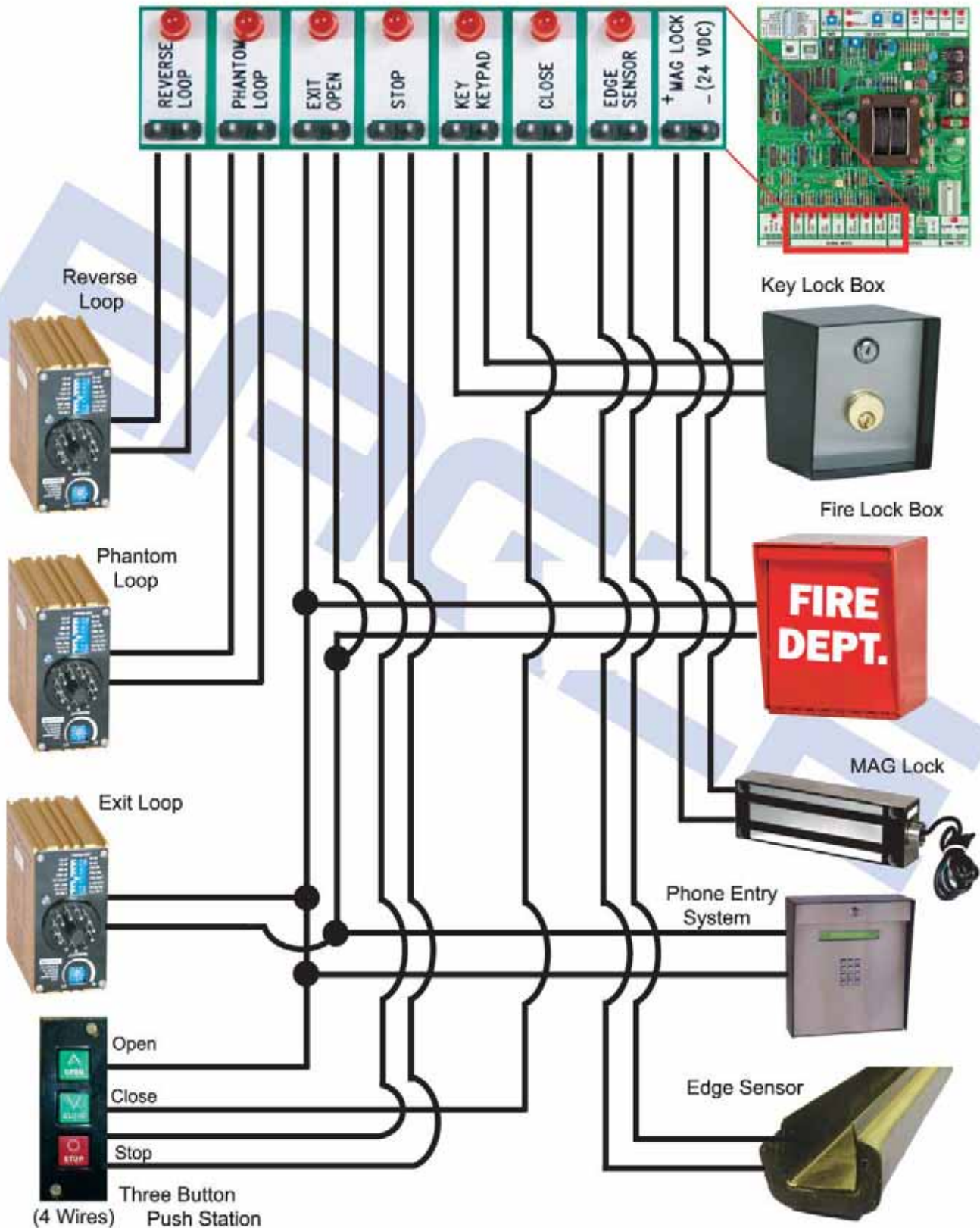

Description of Inputs



1.

Reverse Loop - Momentary or Continuous Signal

This input is active only when the gate is closing or when its fully open. If this input is active, the close timer is disabled. All vehicle detectors and photo-eyes should be connected here. Multiple devices may be connected in parallel.

2.

Phantom Loop - Momentary or Continuous Signal

This input is active only when the gate is at rest in the fully open position. The input has no effect on the gate when fully closed or while closing or opening. Continuous activation will prevent the gate from moving in the close direction. When the input is removed normal operation is resumed. This input is intended for a vehicle loop detector to sense a vehicle in the gate path. Multiple devices may be connected in parallel.

3.

Exit Open / Loop - Momentary or Continuous Input

Once activated the gate will fully open. Activation while the gate is closing will cause the gate to reopen. Continuous activation while the gate is open will disable the timer to close function from automatically closing the gate.

4.

Stop - Momentary or Continuous Signal

This function overrides all other signals. Once activated, the gate will immediately stop and await a new command. If the stop input is continuously activated, the gate will not move.

5.

Key / Keypad

Timer On - Momentary or Continuous Input

Once activated the gate will fully open. Activation while the gate is closing will cause the gate to reopen. Continuous activation while the gate is open will disable the timer to close function from automatically closing the gate.

5.

Key / Keypad (Continued)

Timer Off - Momentary Input

This function must be released and reentered to be recognized. This input is to be used for COMMAND OPEN / COMMAND CLOSE applications. The first signal will cause the gate to begin opening. The second signal will close the gate only when the gate is in the fully open position.

6.

Close - Momentary or Continuous Signal

Once activated the gate will fully close. Activation while the gate is opening has no effect.

7.

Edge Sensor - Momentary or Continuous Signal

This signal is active when the gate is opening and/or closing.

If activated when the gate is opening:

The gate will stop, pause and reverse in the close direction for 1 1/2 seconds and stop. Continuous activation will prevent the gate from moving in the opening direction. If the second activation occurs before the limit switch is activated, the gate will stop and reverse direction for 1 1/2 seconds and stop, thus activating the alarm mode. At this point the operator must be manually reset (ON/OFF) before normal operation can resume.

If activated when the gate is closing:

The gate will stop, pause and fully reopen. During this mode the timer to close, reverse loop, exit loop and phantom loop are disabled. The Key / Keypad and Receiver will cause the gate to close if a second activation occurs before the limit switch is activated. The gate will then stop and reverse direction for 1 1/2 seconds, stop again, thus activating the alarm mode. At this point the operator must be manually reset (ON/OFF) before normal operation can resume.

Multiple devices may be connected in parallel to the Edge Sensor Input.

Receiver Connections

Receiver terminal is mounted on the control box for easy installation and is pre-wired for a 3-wire or a 4-wire receiver.

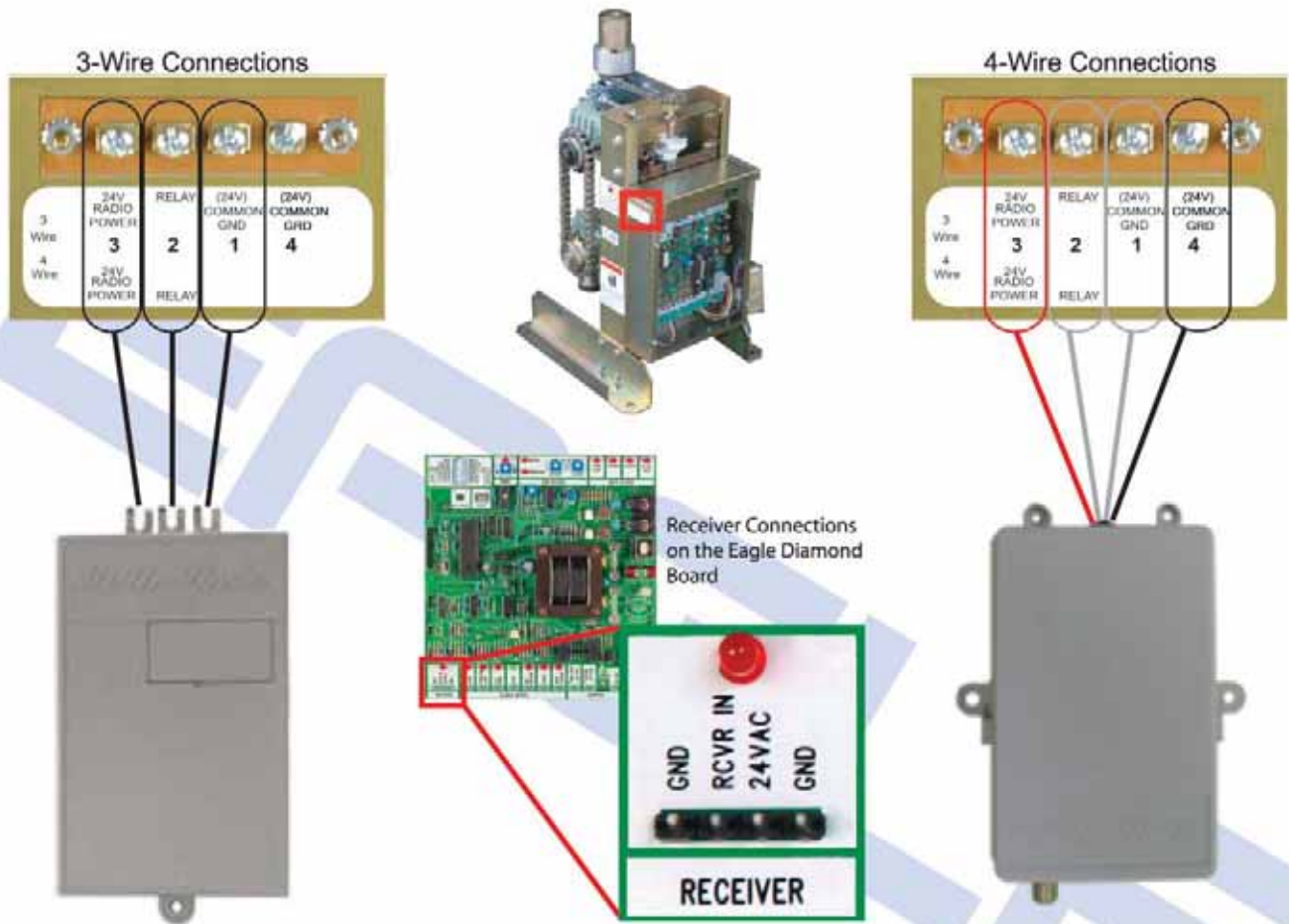

Gate Travel Distance / Setting The Limit Switches

The limit switches must be set so that the gate stops at the proper position. Follow these instructions to appropriately set the limit switches.

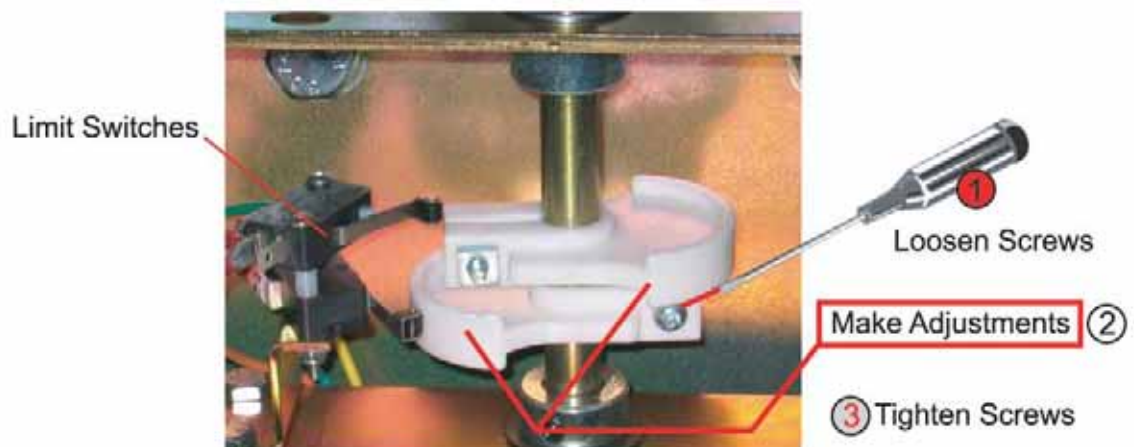

Emergency Release



To release operator, simply unscrew bolt, remove the top cap, and open the Easy Release Lever.



Resetting The Motor



On all Eagle Access motors, a **red** reset button is available for resetting the motor. If operator ceases to function:

TURN THE POWER TO THE OPERATOR OFF AND ALLOW FOR THE MOTOR TO COOL DOWN...

then simply locate the reset button and press.

Adjusting the Operator's Clutch

Depending on the weight of the gate clutch slippage may occur. Typical Clutch slippage is about 1/4 turn. If it does not slip, readjust the Clutch accordingly.

Use an appropriate wrench to adjust the clutch

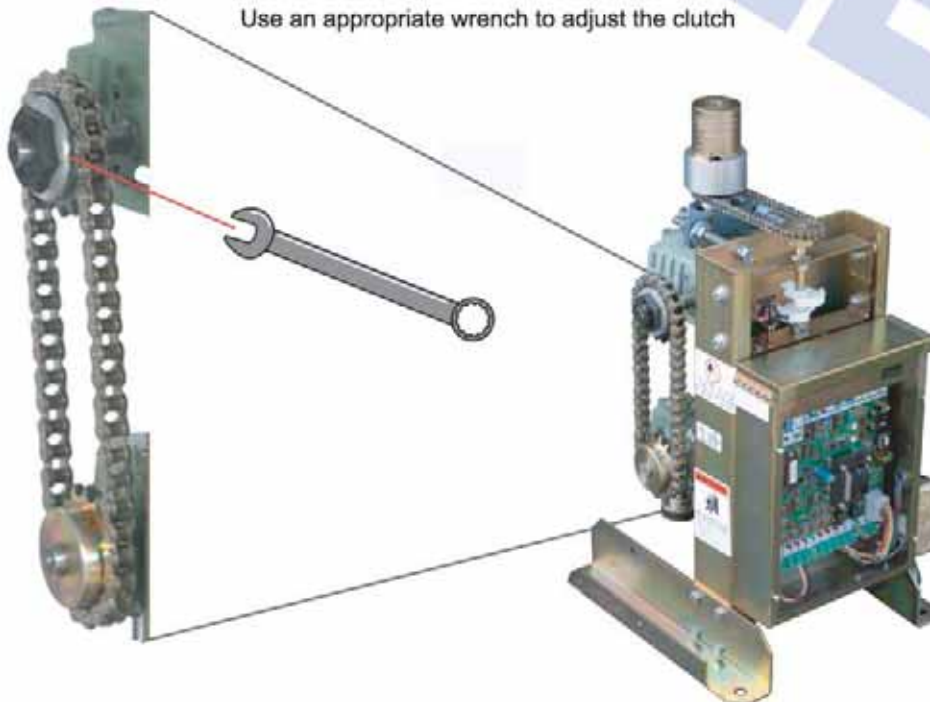

Control Board LED Indicators

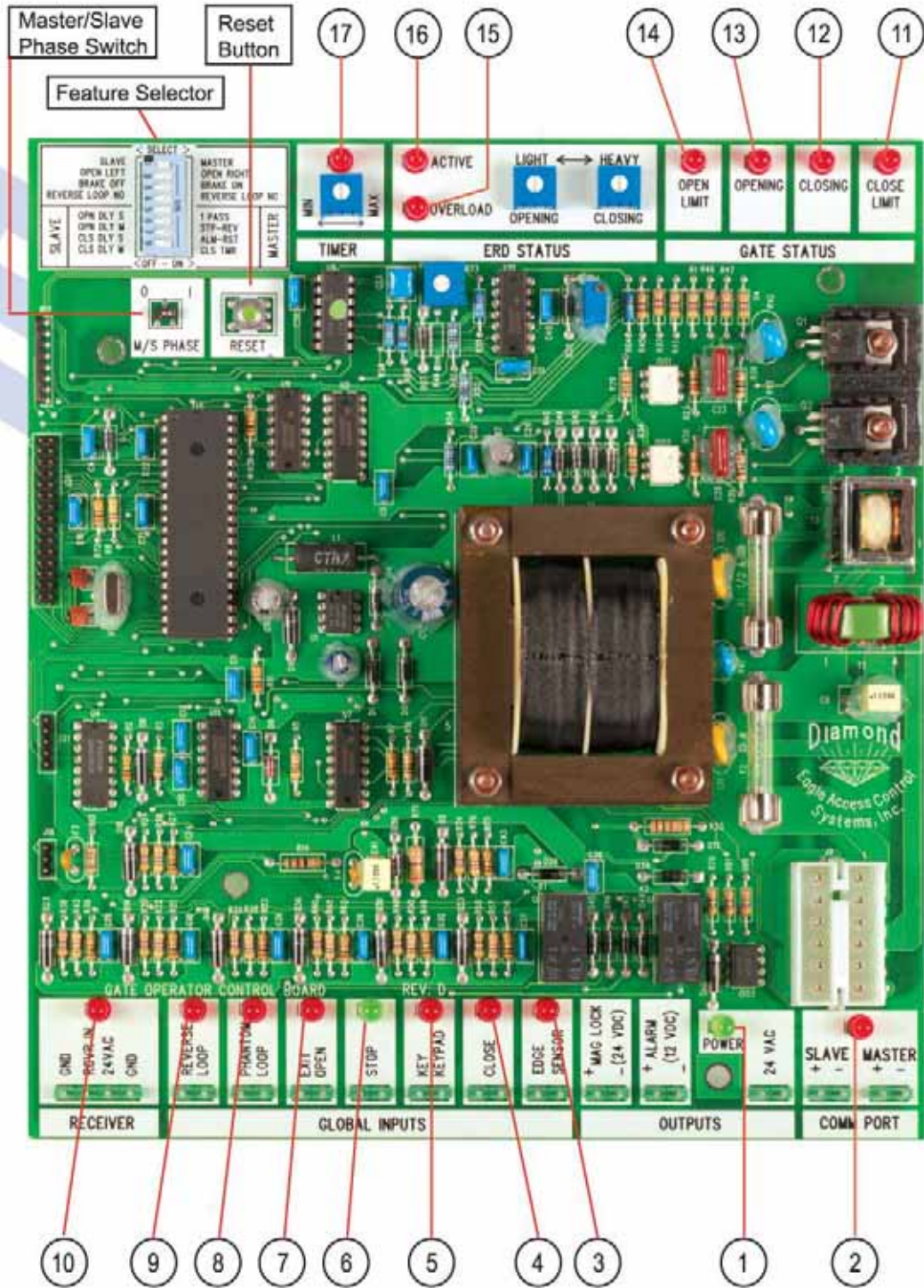

- | | | | |
|---------------------------------|-----------------|-----------------|--------------|
| 1. Power On (Green) | 5. Key / Keypad | 10. Receiver | 15. Overload |
| 2. Master / Slave Communication | 6. Stop (Green) | 11. Close Limit | 16. Active |
| 3. Edge Sensor | 7. Exit / Open | 12. Closing | 17. Timer |
| 4. Close | 8. Phantom Loop | 13. Opening | |
| | 9. Reverse Loop | 14. Open Limit | |

Troubleshooting

SYMPTOMS	PROBABLE CAUSES	REMEDY
<p>Gate stops and reverses direction in mid travel and the OVERLOAD LED remains ON.</p>	<p>(A) Gate operator is not plumb and level. (B) ERD current sense may be set to sensitive. (C) Gate encountered an obstruction while in travel.</p>	<p>(A) Remount operator or chain brackets. (B) Turn the ERD sensor slightly in the clockwise direction. (C) Check and remove all obstructions.</p>
<p>Gate will not CLOSE.</p>	<p>(A) The Radio Receiver's LED remains on. (B) One or more of the global input LED(S) remain active. (C) Gate has reopened because it encountered an obstruction while closing. (D) The Loop Detector LED is on. (E) Switch #8 is not functioning.</p>	<p>(A) Remote or receiver has malfunctioned in the "on" position. (B) Check any Global Inputs for a possible short circuit. (C) Only key/keypad and receiver will resume normal operation. (D) Reset Loop Detector, verify correct wiring, set to a different frequency and/or change the sensitivity of the Loop Detector. (E) Be sure that the "Close Timer" (switch #8) is set to the "on" position.</p>
<p>Gate will not OPEN.</p>	<p>(A) Motor overload. (B) Radio Receiver is not "on" when the remote control is activated. (C) The green LED is "off." (D) Fuse blown.</p>	<p>(A) Reset thermal breaker on motor. (See page 18) (B) The receiver in the gate operator has malfunctioned in the "off" position. (C) Turn "on" the power switch and/or reset the main circuit breaker. (D) Check and/or replace with a proper fuse.</p>

COMMON OVERSIGHTS TO BE AWARE OF:

- (A) Switch #1 must be set to the "Master On" position, unless the operator is being used as a "Slave unit.
- (B) Safety Loop Detectors must be connected to the Reverse Loop input. (See pages 15 & 16)
- (C) If the "Timer to Close" function is desired, switch #8 must be set to the "on" position.
- (D) It is Ok to call the Eagle Access Customer Service Department with any questions...we are here to serve YOU!

1-800-708-8848

Parts Breakdown / Eagle-200

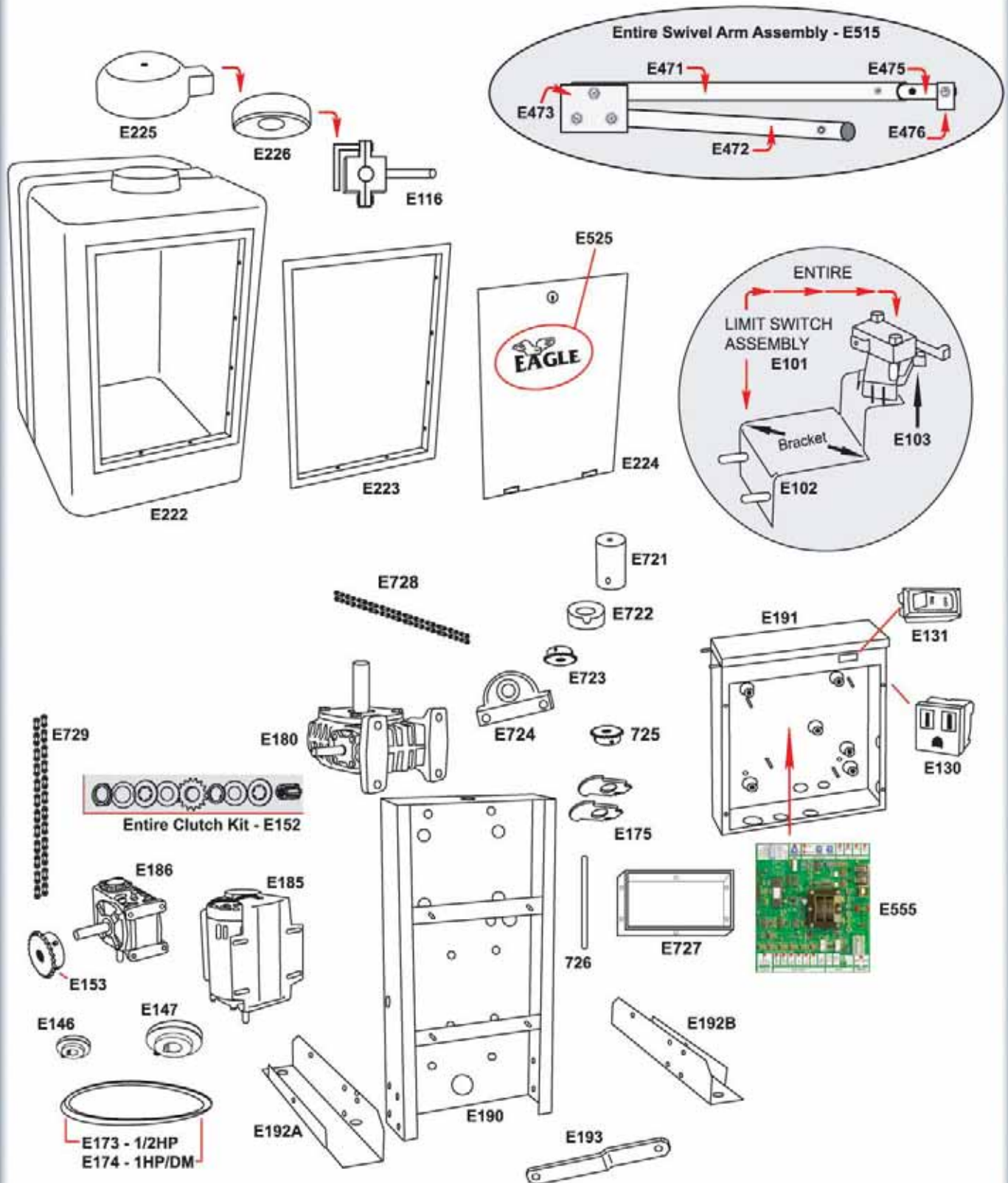

Parts Breakdown / Eagle-100

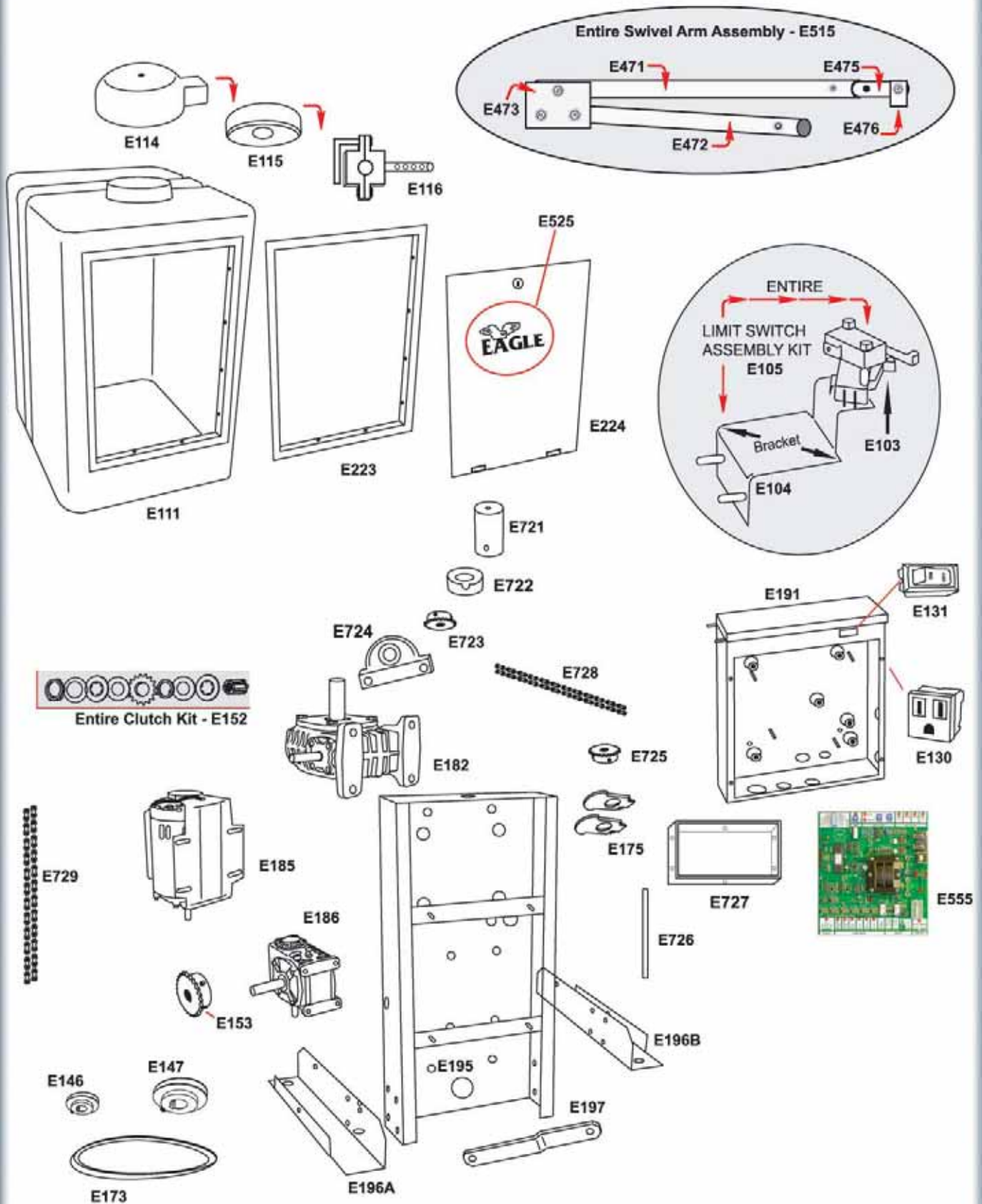

Operator Parts List

Eagle-200 Swing Operator

- E222 - Operator Cover
- E223 - Operator Cover Door Frame
- E224 - Operator Cover Door
- E225 - Release Cover
- E226 - Release Cover Cap
- E116 - Easy Release Main Swing Arm
- E101 - Limit Switch (LS) Assembly (Complete)

E102 - Limit Switch Bracket
E103 - Limit Switches

- E191 - Control Board Box
- E555 - Diamond Control Board
- E130 - Electrical Outlet
- E131 - Power Switch
- E190 - Eagle-200 Chassis
- E192A - Right Chassis Leg
- E192B - Left Chassis Leg
- E193 - Leg Bracket
- E185 - 1/2 HP Motor
- E180 - Primary Gear Reducer (PGR)
- E186 - Secondary Gear Reducer (SGR)
- E723 - (PGR) Sprocket
- E153 - (SGR) Sprocket
- E152 - Clutch Kit (CK) Complete
- E146 - (SGR) Pulley
- E147 - Motor Pulley
- E173 - 1/2HP V-Belt
- E174 - 1HP/DM V-Belt
- E729 - Drive Chain (Side)
- E151 - Drive Chain (Top)
- E721 - Arm Hub
- E726 - Limit Shaft
- E725 - Limit Sprocket
- E724 - Pillow Block
- E727 - Limit Box
- E175 - Limit Switch Activators
- E722 - Aluminum Cup
- E525 - Plastic Eagle Logo
- E515 - Swivel Arm Assembly (SAA) Complete

E471 - Large Arm
E472 - Small Arm
E473 - Arm Attachment Plate
E475 - Extension Arm
E476 - Weld Plate

Left and Right
Determined By Facing
Out From the Operator.

Eagle-100 Swing Operator

- E111 - Operator Cover
- E223 - Operator Cover Door Frame
- E224 - Operator Cover Door
- E114 - Release Cover
- E115 - Release Cover Cap
- E116 - Easy Release Main Swing Arm
- E105 - Limit Switch (LS) Assembly (Complete)

E104 - Limit Switch Bracket
E103 - Limit Switches

- E191 - Control Board Box
- E555 - Diamond Control Board
- E130 - Electrical Outlet
- E131 - Power Switch
- E195 - Eagle-200 Chassis
- E196A - Right Chassis Leg
- E196B - Left Chassis Leg
- E197 - Leg Bracket
- E185 - 1/2 HP Motor
- E148 - 2" Motor Pulley
- E182 - Gear Reducer (GR)
- E186 - Secondary Gear Reducer (SGR)
- E723 - (PGR) Sprocket
- E153 - (SGR) Sprocket
- E146 - (SGR) Pulley
- E147 - Motor Pulley
- E152 - Clutch Kit (CK) Complete
- E141 - Drive Chain
- E724 - Pillow Block
- E172 - 1/2HP V-Belt
- E729 - Drive Chain (Side)
- E728 - Drive Chain (Top)
- E721 - Arm Hub
- E725 - Limit Sprocket
- E726 - Limit Shaft
- E175 - Limit Switch Activators
- E727 - Limit Box
- E722 - Aluminum Cup
- E525 - Plastic Eagle Logo
- E515 - Swivel Arm Assembly (SAA) Complete

Left and Right
Determined By Facing
Out From the Operator.

E471 - Large Arm
E472 - Small Arm
E473 - Arm Attachment Plate
E475 - Extension Arm
E476 - Weld Plate

If you are uncertain of a specific part you need, please call us at the number below for assistance.

Eagle Access Control Systems, Inc.

Eagle Access Control Systems, Inc. designs its gate operators with the dealer/installer in mind, constructing all Eagle operators to be easy to install and to service. From our very first operator, the Eagle-2000, with its superb features and easy to install construction, to the full range of commercial and residential sliding and swing gate operators we now offer, Eagle Access has always provided what our customers need. As our number of distributors grows, we are committed now more than ever to full and effective customer service. If you have any questions or concerns regarding any of our products, please do not hesitate to contact us.

Toll Free (800)708-8848

Phone (818)899-2777

Fax (818)899-2666

Address:

13286-90 Paxton St.
Pacoima, CA 91331

www.eagleoperators.com

